

### Product Summary

The GESDN5V0D51 is Designed to protect voltage sensitive electronic components from ESD and other transients. Excellent clamping capability, low leakage, and fast response time provide best in class protection on designs that are exposed to ESD.

The combination of small size, high level of ESD protection makes them a flexible solution for applications such as Digital cameras ,cellular phones, and MP3 Players. It is designed to replace multiplayer varistors (MLV) in consumer equipments applications such as mobile phone, notebook, PAD, STB, LCD TV etc.

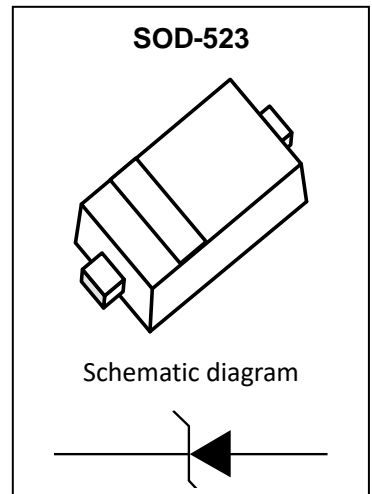

### Feature

- Low reverse stand-off voltage:5V
- Low reverse clamping voltage
- Low leakage current
- Fast response time
- JESD22-A114-B ESD Rating of class 3B per human body model
- IEC 61000-4-2 Level 4 ESD protection

### Application

- Computers and peripherals
- Portable electronics
- Power lines
- Audio and video equipment
- Cellular handsets and accessories
- Other electronic equipment communication systems

### Marking:



Front Side  
 N5 =Device Code

## Absolute Maximum Ratings ( $T_A=25^{\circ}\text{C}$ unless otherwise noted)

Parameter	Symbol	Value	Unit
IEC 61000-4-2 ESD Voltage	$V_{\text{ESD}}^{1)}$	$\pm 30$	kV
IEC 61000-4-2 ESD Voltage		$\pm 30$	
JESD22-A114-B ESD Voltage		$\pm 16$	
ESD Voltage		$\pm 0.4$	
Peak Pulse Power	$P_{\text{PP}}^{2)}$	100	W
Peak Pulse Current	$I_{\text{PP}}^{2)}$	8	A
Lead Solder Temperature – Maximum (10 Second Duration)	$T_L$	260	$^{\circ}\text{C}$
Junction Temperature	$T_j$	150	$^{\circ}\text{C}$
Storage Temperature	$T_{\text{stg}}$	-55~ +150	$^{\circ}\text{C}$

- 1) Device stressed with ten non-repetitive ESD pulses.
- 2) Non-repetitive current pulse 8/20 $\mu\text{s}$  exponential decay waveform according to IEC61000-4-5.

## ESD standards compliance

### IEC61000-4-2 Standard

Contact Discharge		Air Discharge	
Level	Test Voltage kV	Level	Test Voltage kV
1	2	1	2
2	4	2	4
3	6	3	8
4	8	4	15

### JESD22-A114-B Standard

ESD Class	Human Body Discharge V
0	0~249
1A	250~499
1B	500~999
1C	1000~1999
2	2000~3999
3A	4000~7999
3B	8000~15999

### Contact discharge current waveform per IEC61000-4-2

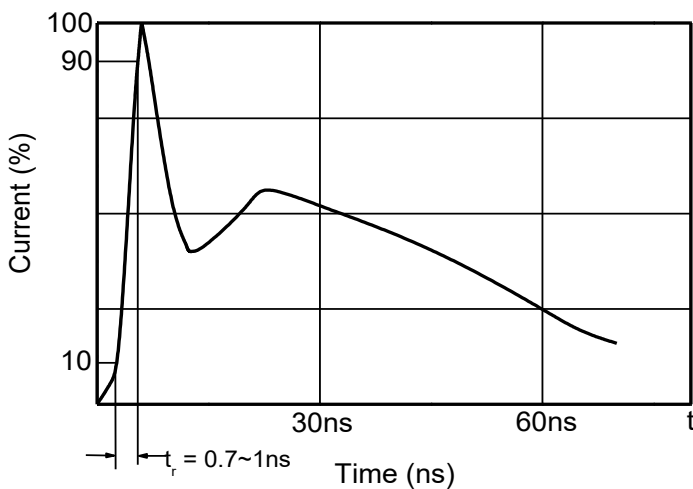

### 8/20 $\mu\text{s}$ waveform per IEC61000-4-5

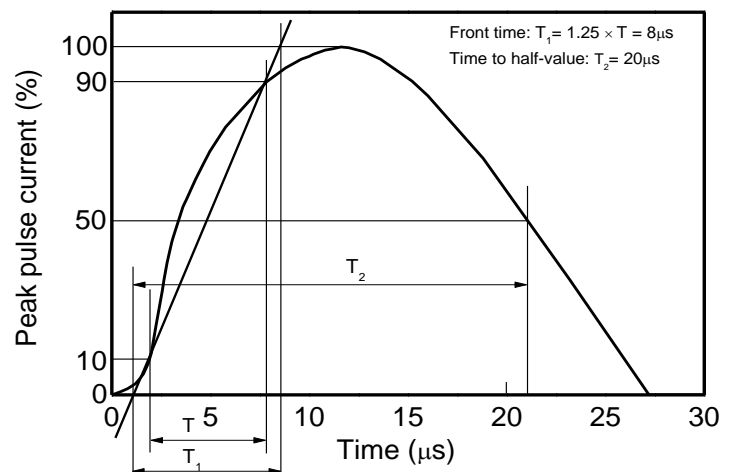

## Electrical Parameter

Symbol	Parameter
V <sub>C</sub>	Clamping Voltage @ I <sub>PP</sub>
I <sub>PP</sub>	Peak Pulse Current
V <sub>BR</sub>	Breakdown Voltage @ I <sub>T</sub>
I <sub>T</sub>	Test Current
I <sub>R</sub>	Reverse Leakage Current @ V <sub>RWM</sub>
V <sub>RWM</sub>	Reverse Standoff Voltage

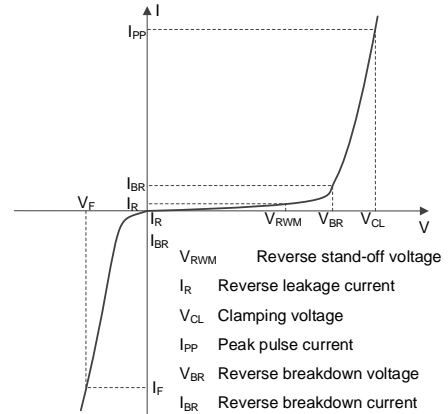

V-I characteristics for a Uni-directional TVS

## Electrical Characteristics (T<sub>A</sub>=25°C unless otherwise specified)

Parameter	Symbol	Test conditions	Min	Typ	Max	Unit
Reverse stand-off voltage	V <sub>RWM</sub> <sup>1)</sup>				5	V
Reverse leakage current	I <sub>R</sub>	V <sub>RWM</sub> =5V			1	uA
Forward Voltage	V <sub>F</sub>	I <sub>F</sub> =10mA			1.0	V
Breakdown voltage	V <sub>BR</sub>	I <sub>T</sub> =1mA	6		9.5	V
Clamping voltage	V <sub>C</sub> <sup>2)</sup>	I <sub>PP</sub> =1A		7.8	9.5	V
		I <sub>PP</sub> =8A		10.5	12.5	V
Junction capacitance	C <sub>J</sub>	V <sub>R</sub> =0V, f=1MHz		60		pF

- 1) Other voltages available upon request.
- 2) Non-repetitive current pulse 8/20μs exponential decay waveform according to IEC61000-4-5

## Typical Characteristics

**$V_C$  vs.  $I_{PP}$**

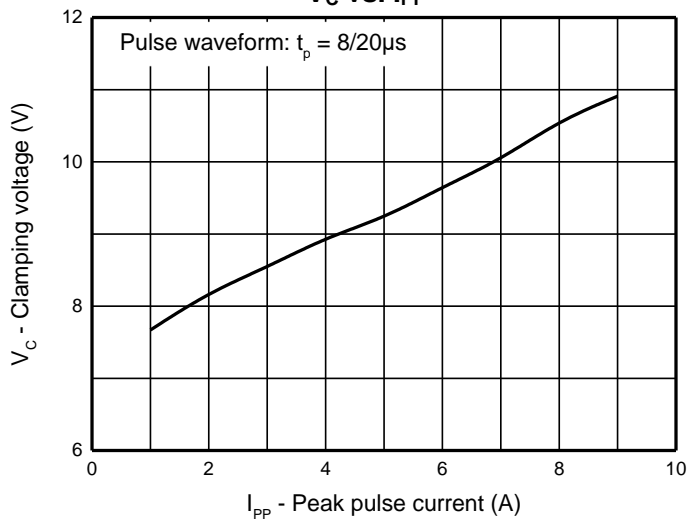

**I-V Curve**

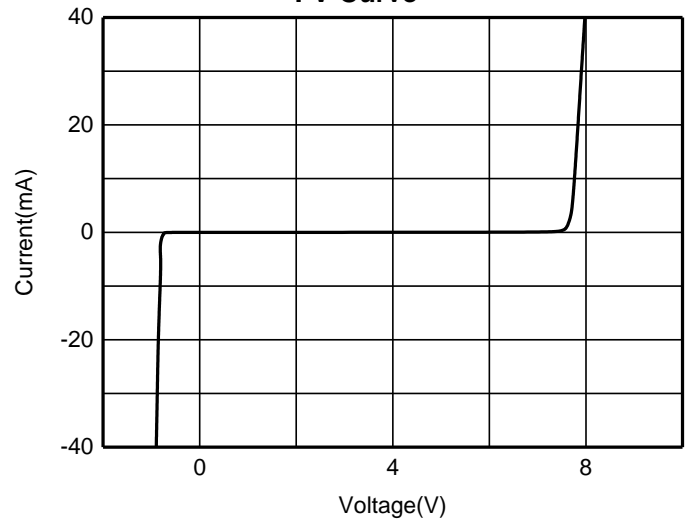

**Peak pulse power vs. Pulse time**

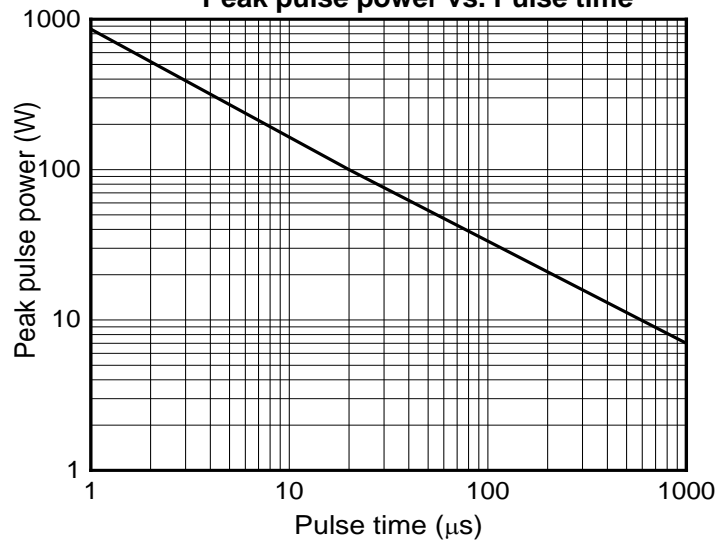

**Power derating vs. Ambient temperature**

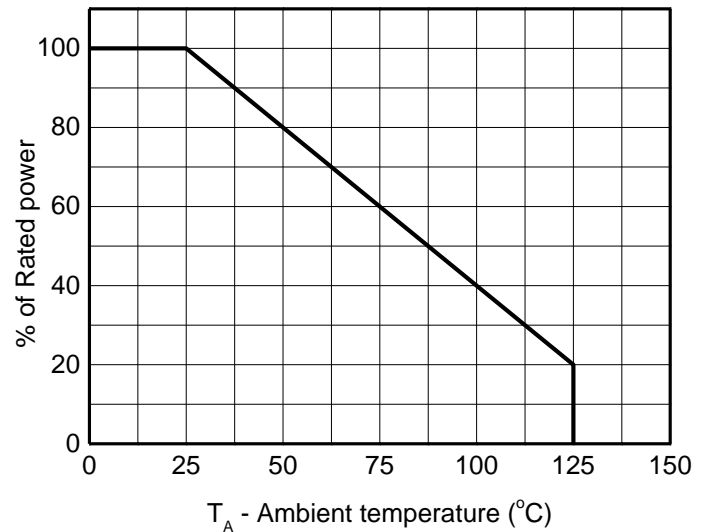

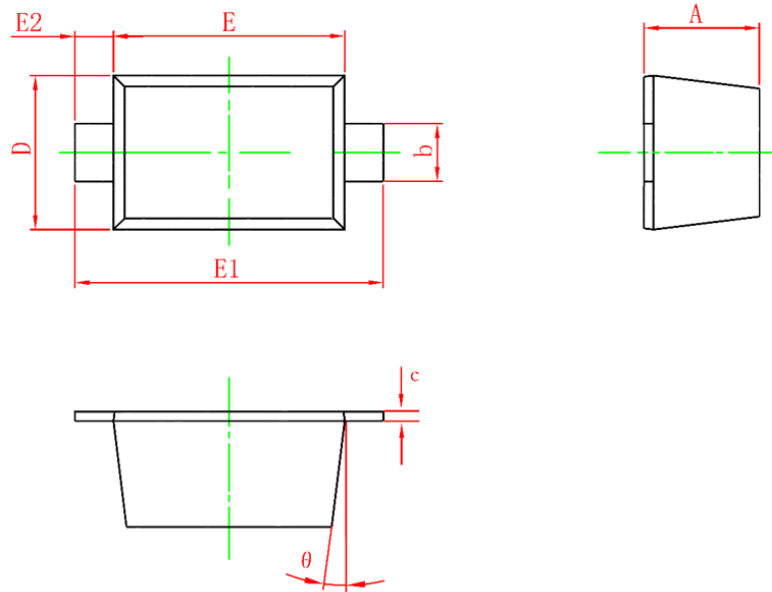
**SOD-523 Package Outline Dimensions**

Symbol	Dimensions In Millimeters		Dimensions In Inches	
	Min.	Max.	Min.	Max.
A	0.470	0.770	0.018	0.030
b	0.250	0.350	0.010	0.014
c	0.080	0.150	0.003	0.006
D	0.750	0.850	0.030	0.033
E	1.100	1.300	0.043	0.051
E1	1.500	1.700	0.059	0.067
E2	0.200REF		0.008REF	
θ	7°REF		7°REF	